



## PRODUCT SPECIFICATIONS

Direct plug to wall outlet with 8' cord

4 ACH (air changes per hour) in 200 sq.ft. room

Unit weight ~ 17 lbs.

4 fan speed settings

LED indicators for lamp replacement notification and diagnosis

Rubber anti-slide base feet

2 color options (primary / secondary)  
Purple / Silver  
White / Purple

10,000-hour rated UVC quartz lamp\*

5-Year Warranty



**nU**  
**Vo**<sup>TM</sup>

### UV-C AIR DISINFECTION TOWER

The nUvo<sup>TM</sup> free-standing air disinfection tower uses enclosed high-power ultraviolet light (UV-C) designed to destroy airborne pathogens including 99.9%+ of coronavirus.

### FEATURES AND BENEFITS

- Onboard 4-speed fan sized for 4 ACH (air changes per hour)
- 120 VAC, 50/60 Hz compatibility
- No filter changes required
- ETL and CE certifications pending
- Engineered to kill at least 99.9% of airborne pathogens such as SARS-COV-2
- Disinfection power to be verified by third party agency

\*Quartz blocks the creation of harmful Ozone



PRODUCT SPECIFICATION

Product	SKU	Description
Room Unit	NUVO-AT-PS	Air disinfection tower, purple/silver
Room Unit	NUVO-AT-WP	Air disinfection tower, white/purple

Sizes

Free-Standing Tower

- \* 86 Watt fluorescent lamp with equivalent 35 Watt UV-C (254nm) optical power output
- \* 120 CFM fan (approximately 4 air changes per hour for 200-sq.ft. space)

Housing

Sleek modern design offered in 2 color schemes:

- \* Purple with silver accents
- \* White with purple accents

DIAGRAM

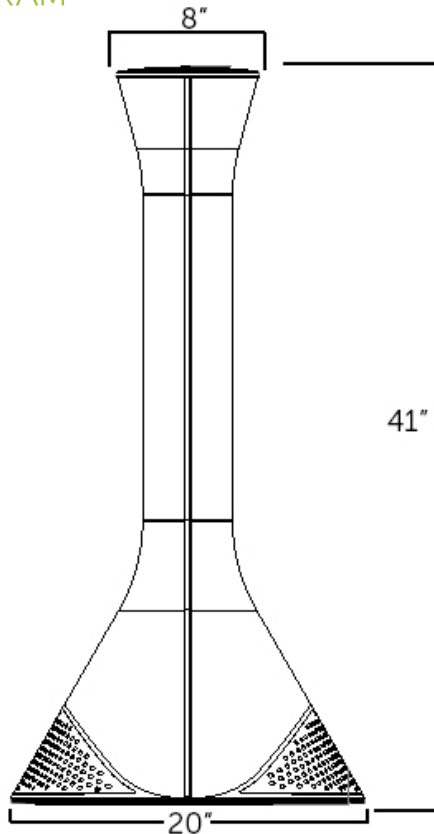

UV in the Electromagnetic Spectrum

